

# Indicator Stop/Tail – Amber/Red

## BL-207ARM BRITE LED TECH PRODUCT

Certified Design registration number : 319069

Water Proof, Shock Proof, Vibration Proof, Rust Proof

5 Years Warranty

Complies With ADR 47/00, 49/00 and 6/00 Cat 2a (Horizontal fitment)

Amber/Red Stop/Tail Indicator Lamp M/Volt 12 Volt / 24 Volt unit with 24 LED's 12 Red LED's and 12 Amber LED's with polycarbonate lens Black Base 165mm x 100mm x 32mm with 400mm of wire fitted.

1 unit per Blister pack.

Ideal for: Bus, Car, Caravans, Trailers & Trucks

Also Available in 9 meter cable kits

2 lamps with 9 meter cable trailer kit BL-207-KIT

2 x 9 meter cable lamps 1 with BL-310M hardwired BL-207-KIT1N

Length	165mm
Width	100mm
Height	32mm
Voltage	12 Volt & 24 Volt
Power Draw Tested @ 13.8 V	Indicator 0.13 Amps Stop 0.14 Amps / Tail 0.04 Amps
Pieces Per Card Packing	1 Unit Blister Packed on Card



BL-207ARM

Can fit BL-310M number Plate Light as shown below (BL-310M not supplied but can be purchased separately)

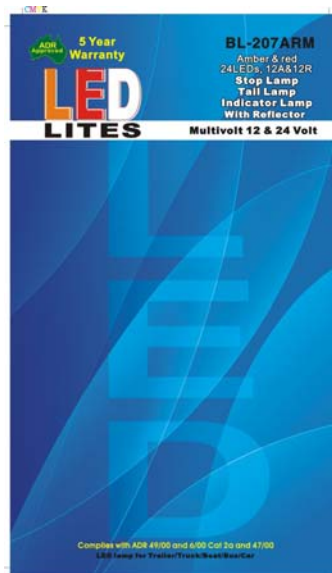
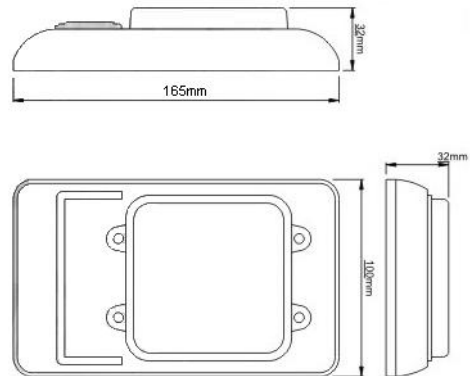

BL-207ARM  
BRITE LED TECH PTY LTD  
100% Australian Owned Company

**Features:**  
\*Overall size: 165X100X32mm  
\*400mm of Wire  
\*24LED's: 12Amber & 12Red  
\*Multivolt 12 & 24 Volt Applications  
\*with Reflector  
\*Super bright LED, more vivid colors and clear visible light  
\*Lower power consumption  
\*Less Heat Produced  
\*Quick Response to illuminate  
\*Easy installation  
\*Fully Submersible  
\*Full 5 Year Replacement Warranty on this product

Waterproof, Shockproof, Vibrationproof, Rustproof

**INSTALLATION:**

Wiring Diagram  
White-Earth  
Red-Stop  
Brown-Tail  
Yellow-Indicator

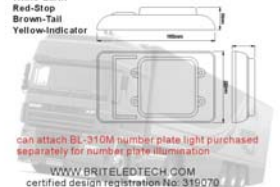

can attach BL-310M number plate light purchased separately for number plate illumination  
WWW.BRITELEDETECH.COM  
certified design registration No. 319070